

LOW DROP POWER SCHOTTKY RECTIFIER

MAIN PRODUCT CHARACTERISTICS

I_{F(AV)}	0.5 A
V_{RRM}	20 V
T_j (max)	150°C
V_F (max)	0.30 V

FEATURES AND BENEFITS

- Very small conduction losses
- Negligible switching losses
- Extremely fast switching
- Low forward voltage drop for higher efficiency & extended battery life
- Low thermal resistance

DESCRIPTION

Single Schottky rectifier suited for switch mode power supplies and high frequency DC to DC converters.

Packaged in ST Mite, this device is intended for use in low voltage, high frequency inverters, free wheeling and polarity protection applications. Due to the small size of the package this device fits battery powered equipment (cellular, notebook, PDA's, printers) as well chargers and PCMCIA cards.

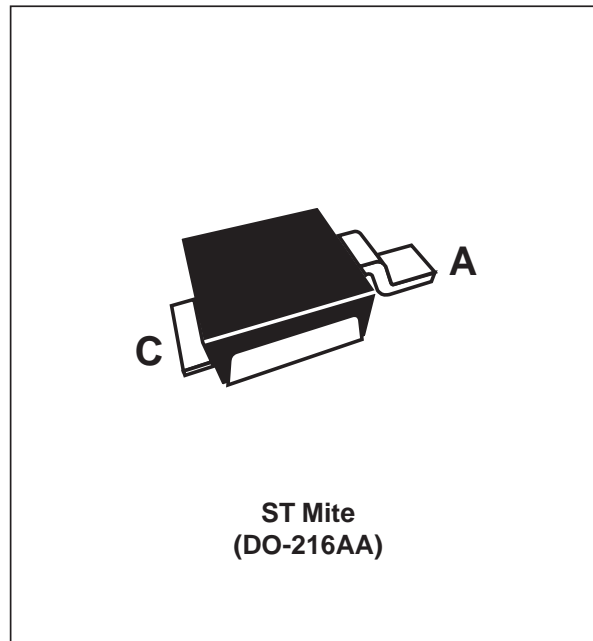

ABSOLUTE RATINGS (limiting values)

Symbol	Parameter		Value	Unit
V _{RRM}	Repetitive peak reverse voltage		20	V
I _{F(RMS)}	RMS forward current		2	A
I _{F(AV)}	Average forward current	T _c = 140°C δ = 0.5	0.5	A
I _{FSM}	Surge non repetitive forward current	10 ms sinusoidal	5.5	A
T _{stg}	Storage temperature range		- 65 to + 150	°C
T _j	Maximum operating junction temperature*		150	°C
dV/dt	Critical rate of rise of reverse voltage (rated V _r , T _j = 25°C)		10000	V/μs

* : $\frac{dP_{tot}}{dT_j} < \frac{1}{R_{th(j-a)}}$ thermal runaway condition for a diode on its own heatsink

STPS0520M

THERMAL RESISTANCE

Symbol	Parameter	Value	Unit
$R_{th(j-c)}^*$	Junction to case	20	°C/W
$R_{th(j-a)}^*$	Junction to ambient	250	°C/W

* Monted with minimum recommended pad size, PC board FR4.

STATIC ELECTRICAL CHARACTERISTICS

Symbol	Parameter	Tests conditions		Value			Unit
				Min.	Typ.	Max.	
I_R^*	Reverse leakage current	$T_j = 25^\circ\text{C}$	$V_R = V_{RRM}$		15	50	μA
		$T_j = 100^\circ\text{C}$			2	6	mA
		$T_j = 25^\circ\text{C}$	$V_R = 10\text{ V}$		7	25	μA
		$T_j = 100^\circ\text{C}$			1	3	mA
V_F^*	Forward voltage drop	$T_j = 25^\circ\text{C}$	$I_F = 0.1\text{ A}$		0.30	0.33	V
		$T_j = 100^\circ\text{C}$			0.195	0.23	
		$T_j = 25^\circ\text{C}$	$I_F = 0.5\text{ A}$		0.35	0.385	
		$T_j = 100^\circ\text{C}$			0.26	0.30	

Pulse test : * $t_p \leq 380\ \mu\text{s}$, $\delta \leq 2\%$

To evaluate the conduction losses use the following equation :

$$P = 0.34 \times I_{F(AV)} + 0.07 I_{F(RMS)}^2$$

Fig. 1: Conduction losses versus average current.

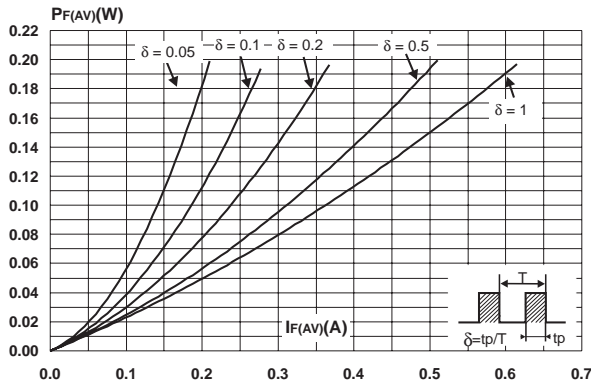

Fig. 2: Average forward current versus ambient temperature ($\delta = 0.5$)

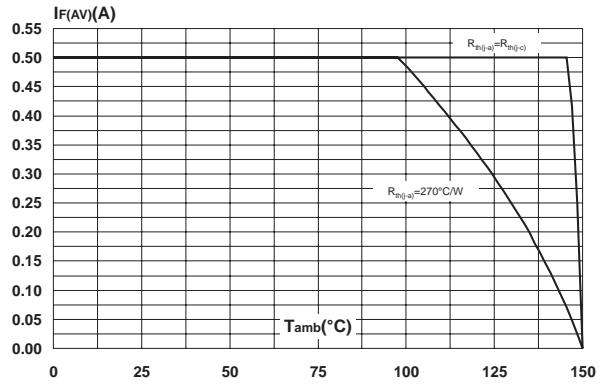

Fig. 3: Non repetitive surge peak forward current versus overload duration (maximum values).

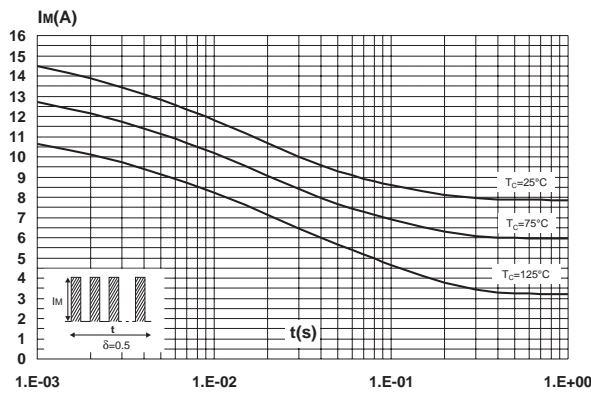

Fig. 4: Relative variation of thermal impedance junction to case versus pulse duration.

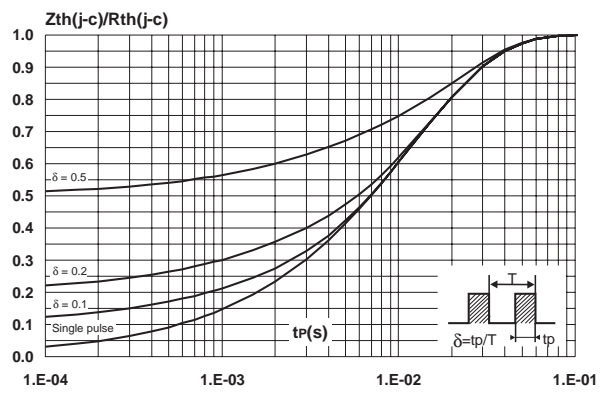

Fig. 5: Reverse leakage current versus reverse voltage applied (typical values).

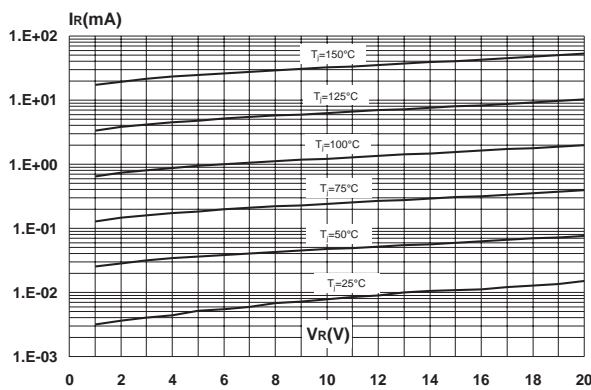

Fig. 6: Reverse leakage current versus junction temperature (typical values).

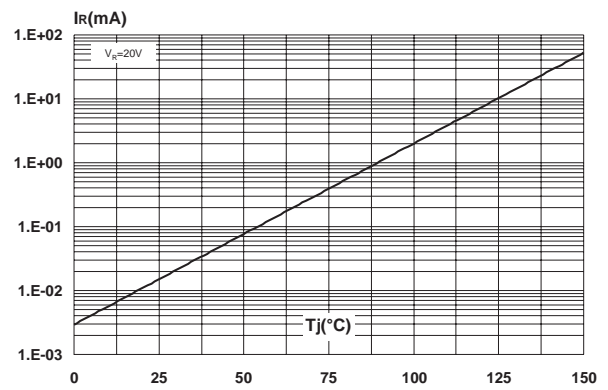

Fig. 7: Junction capacitance versus reverse voltage applied (typical values).

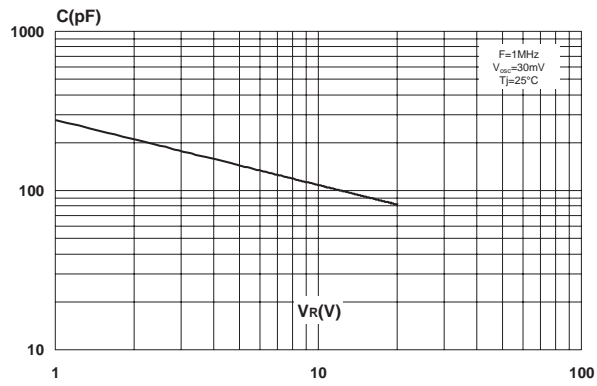

Fig. 8: Forward voltage drop versus forward current.

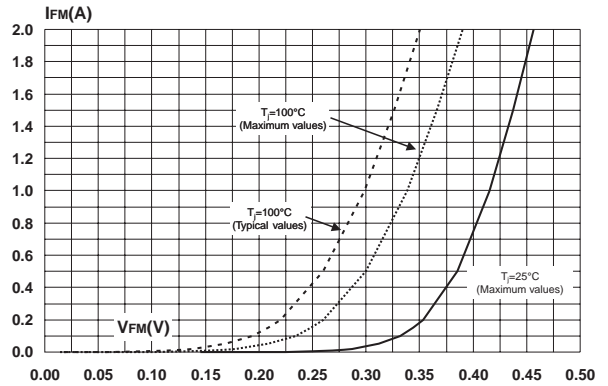
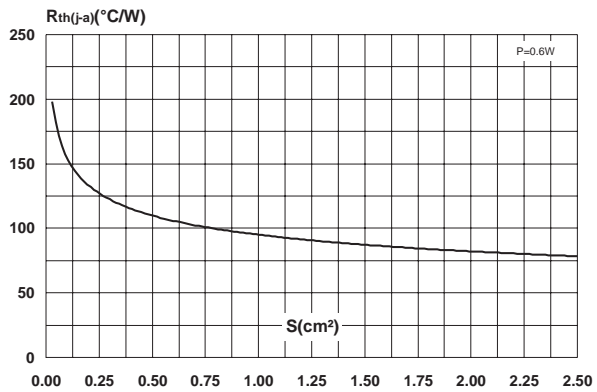

Fig. 9: Thermal resistance junction to ambient versus copper surface under tab (epoxy printed board FR4, Cu = 35 μm , typical values).



PACKAGE MECHANICAL DATA

ST Mite

REF.	DIMENSIONS					
	Millimeters			Inches		
	Min.	Typ.	Max.	Min.	Typ.	Max.
A	0.85	1.00	1.15	0.033	0.039	0.045
A1			0.10			0.004
b	0.40		0.65	0.016		0.025
b2	0.70		1.00	0.027		0.039
c	0.10		0.25	0.004		0.010
D	1.75	1.90	2.05	0.069	0.007	0.081
E	1.75	1.90	2.05	0.069	0.007	0.081
H	3.60	3.75	3.90	0.142	0.148	0.154
L	0.50	0.63	0.80	0.047	0.025	0.031
L2	1.20	1.35	1.50	0.047	0.053	0.059
L3	0.50 ref (Typ.)			0.019 ref (Typ.)		
R	0.07			0.003		
R1	0.07			0.003		

Note: The anode is connected to the longer tab
The cathode is connected to the shorter tab (heatsink)

FOOTPRINT (dimensions in mm)

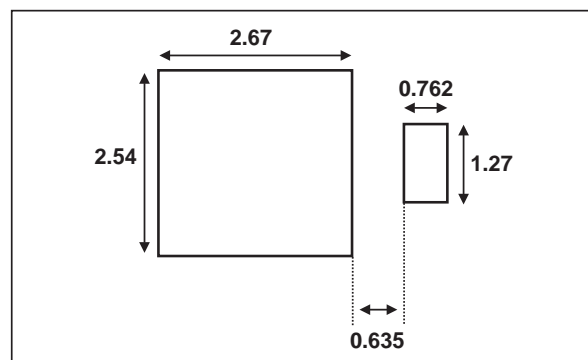

STPS0520M

Type	Marking	Package	Weight	Base qty	Delivery mode
STPS0520M	052	ST Mite	15.5 mg	12000	Tape & reel

Information furnished is believed to be accurate and reliable. However, STMicroelectronics assumes no responsibility for the consequences of use of such information nor for any infringement of patents or other rights of third parties which may result from its use. No license is granted by implication or otherwise under any patent or patent rights of STMicroelectronics. Specifications mentioned in this publication are subject to change without notice. This publication supersedes and replaces all information previously supplied. STMicroelectronics products are not authorized for use as critical components in life support devices or systems without express written approval of STMicroelectronics.

The ST logo is a registered trademark of STMicroelectronics

© 2002 STMicroelectronics - Printed in Italy - All rights reserved.

STMicroelectronics GROUP OF COMPANIES

Australia - Brazil - Canada - China - Finland - France - Germany
Hong Kong - India - Israel - Italy - Japan - Malaysia - Malta - Morocco - Singapore
Spain - Sweden - Switzerland - United Kingdom - United States.

<http://www.st.com>